



Installation & User Manual



PREMIUM FULL INVERTER HEAT PUMP



TABLE OF CONTENT

FOR USERS

1. General Information	3-6
1.1 Contents	3
1.2 Operating condition	3
1.3 Advantages of different modes	3
1.4 Kind Reminder	4-6
2. Operations	7-10
2.1 Notice before using	7
2.2 Operation Instructions	7-9
2.3 Maintenance and winterising	10
3. Technical Specification	11

FOR INSTALLERS AND PROFESSIONALS

4. Transportation	12
5. Installation and maintenance	13-20
5.1 Notice before installation	13
5.2 Installation Instructions	14-17
5.3 Trial after Installation	20
5.4 Maintenance and winterising	20
6. Trouble Shooting Guide	21
7. Error Codes	22
8. WiFi Setting	23-28

1. GENERAL INFORMATION

1.1 CONTENTS

After unpacking, please check that you have all the following components.

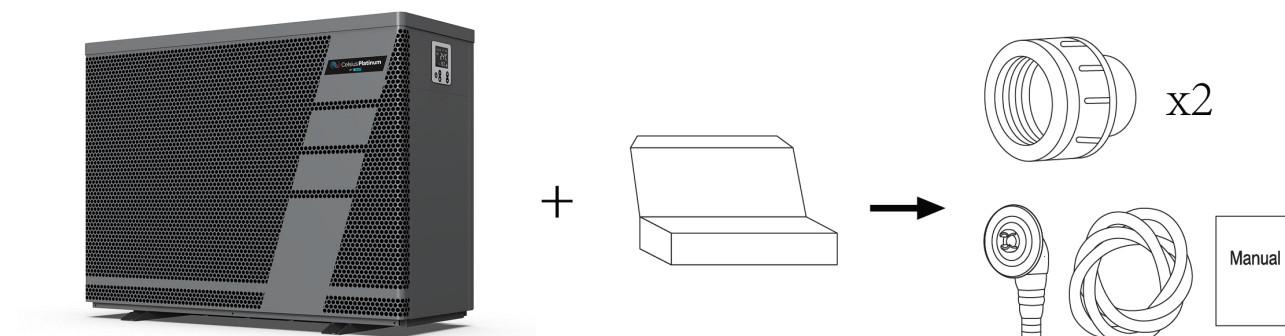

1.2 OPERATING CONDITIONS AND RANGE



Items		Range
Operating Range	Air Temperature	-7°C - 43°C
Temperature Setting	Heating	18°C - 40°C
	Cooling	12°C - 35°C

The heat pump will have ideal performance in the operation range Air 15°C ~ 25°C

Note: Please check compatibility for cooling as this mode is not available on all models

1.3 ADVANTAGES OF DIFFERENT MODES

The heat pump has three modes: Turbo, Smart and Silence
They have different advantages under different conditions

MODE	ADVANTAGES
Turbo mode 	Heating capacity: 120% Fast heating
Smart mode 	Heating capacity: 20% - 100% Intelligent optimization according to ambient temperature and water temperature Energy efficiently saving
Silence mode 	Heating capacity: 20% - 60% Use at night

1.4 KIND REMINDER



ATTENTION

This heat pump has power-off memory function. When the power is recovered, the heat pump will restart automatically.

1.4.1 The heat pump can only be used with pool water. It can NEVER be used to heat or cool other flammable or turbid liquid.

1.4.2 When moving the heat pump, do not lift the water union. This will damage the titanium heat exchanger.

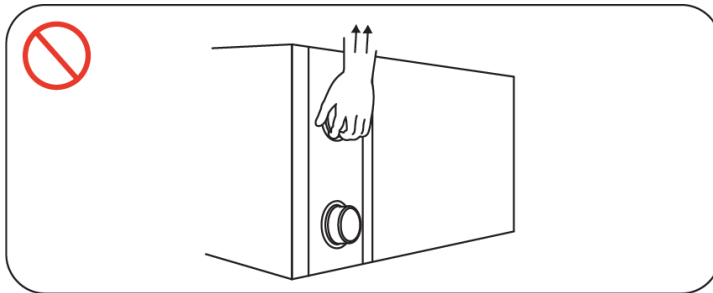

1.4.3 Do not obstruct the air inlet or outlet of the heat pump.

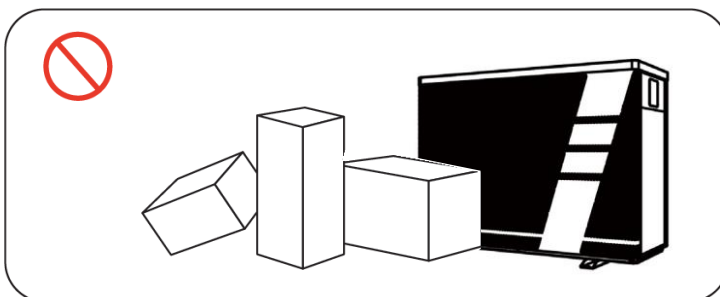

- 1.44 Do not obstruct or insert any objects into inlet or outlet of the heat pump. The efficiency may be reduced or even stopped.

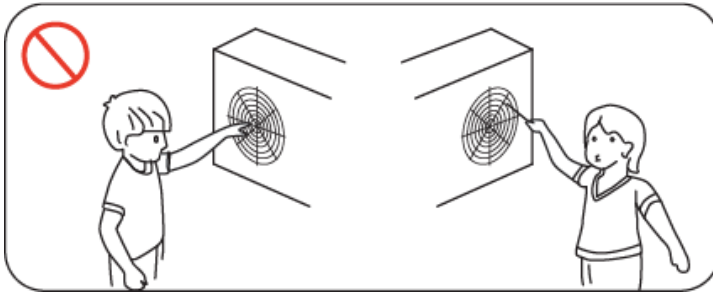

- 1.45 To avoid fire hazards, do not store or use combustible gas or liquids such as thinners, paints or fuels near the heat pump.

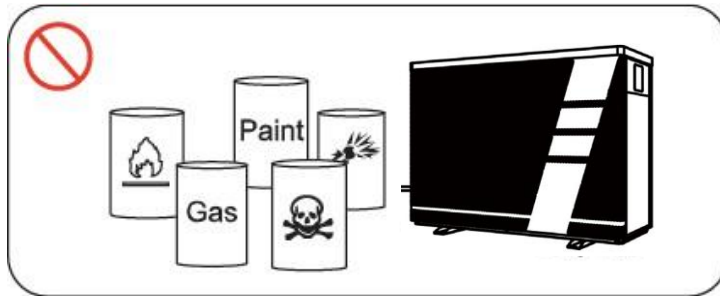

- 1.46 If you detect any abnormal noises, odours, smoke or leaks from the heat pump, immediately switch off the power supply and contact your local dealer. Do not attempt to repair the heat pump yourself.

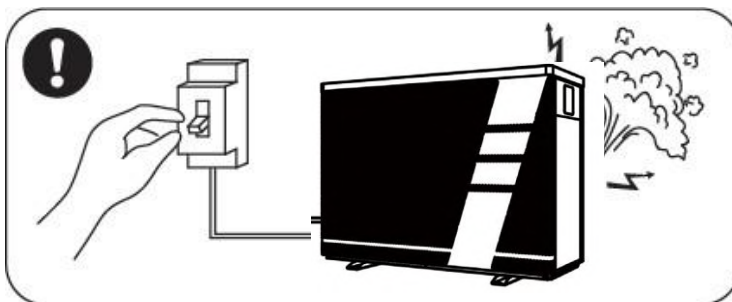

1.4.7 The main power supply switch should be out of the reach of children.

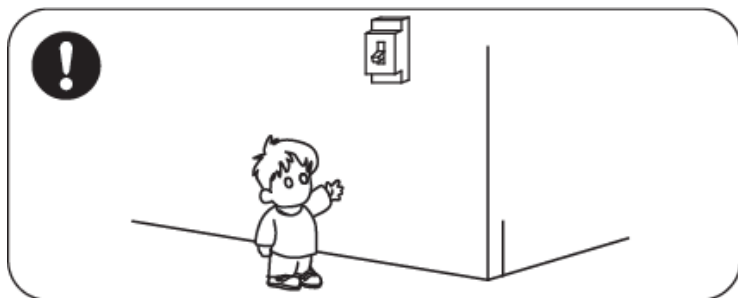

1.4.8 Please disconnect the heat pump from the power supply during electrical storms.

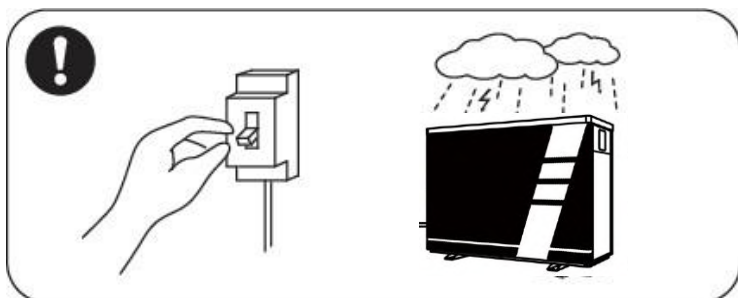

1.4.9 Please note that following codes **are not failures**.

	Codes
No water flow	E3
Anti-freezing reminder	Ed
Out of the operating range	Eb
Insufficient water flow or pump blocked	E6
Power abnormal	E5

2. OPERATIONS

2.1 NOTICE BEFORE USING

- 1 To optimise the life cycle of the system, the user is advised to start the water pump before the heat pump, and turn off the heat pump before the water pump.
- 2 Check for any water leakage in connecting pipework, then turn on the power supply, press the ON/OFF button of the heat pump, and set desired temperature.



2.2 OPERATION INSTRUCTIONS

Symbol	Designation	Operation
	Power ON/OFF	Power On/Off
	Unlock/ Mode	<ol style="list-style-type: none">1. Press it for 3 seconds to unlock/lock screen2. After screen is unlocked, press it to select mode<ul style="list-style-type: none">• Auto (12~40°C)• Heating (18~40°C)• Cooling (12~30°C)
	Speed	Select Turbo/Smart/Silence mode
	Up / Down	Adjust set temperature

Note: Please check compatibility for cooling as this mode is not available on all models

NOTE





1 Screen lock

- a) If no operation in 30 seconds, screen will be locked.
- b) When Heat Pump is off, screen will be dark and "0%" will be displayed.

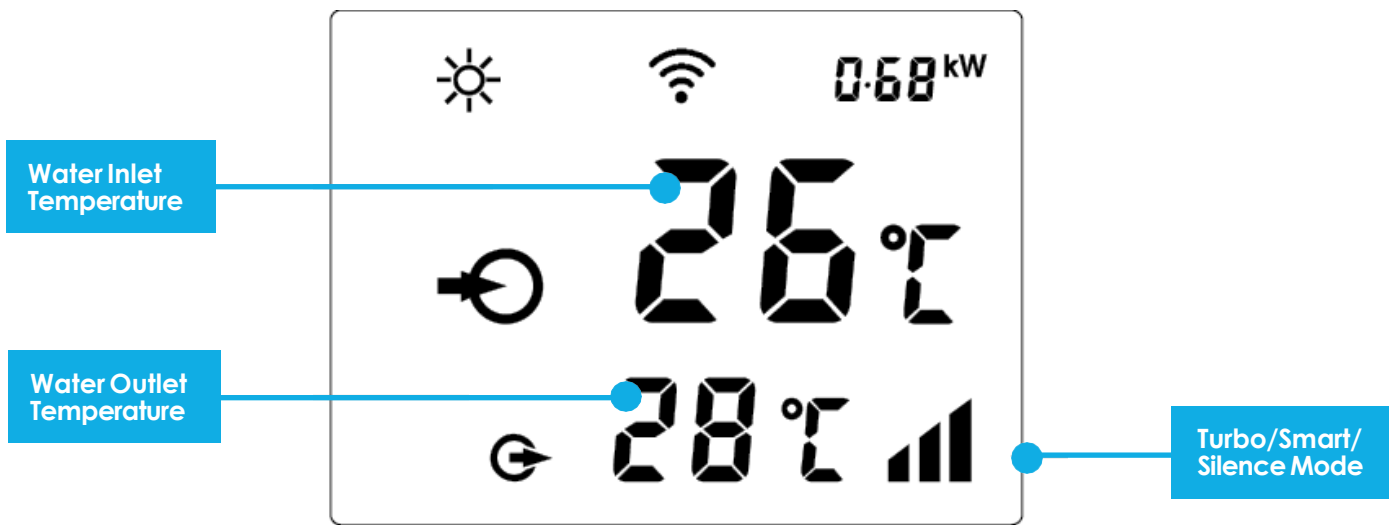

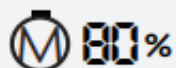
2 Screen unlock

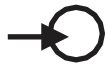
- a) Press  for 3 seconds to unlock screen. The screen will illuminate
- b) All other buttons are only functional after the screen is unlocked.



Symbol	Operation
	Heating
	Heating capacity percentage
0.68 kW	Real-time power consumption display
	Wifi connection
	Water inlet
	Water outlet

1 Power On

Press  for 3 seconds to unlock screen, then press  to power on heat pump.

2 Adjust Set Temperature

When screen is unlocked, press  or  to display or adjust the set temperature.







3 Mode Selection

Press  to select modes.







- a) Auto: Adjustable temperature range 12~40°C
- b) Heating: Adjustable temperature range 18~40°C
- c) Cooling: Adjustable temperature range 12~30°C

Note: Please check compatibility for cooling as this mode is not available on all models

4 Turbo/Smart/Silence mode selection:

- Smart mode as default will be activated when heat pump is on, and screen shows 
- Press  to enter Turbo mode, and screen shows  then press  to enter Silence mode, the screen shows . Press  again, the screen shows  and return to Smart mode.

5 Defrosting

- Auto Defrosting: When heat pump is defrosting,  will be flashing. After defrosting,  will stop flashing.
- Compulsory Defrosting: When heat pump is heating, press  and  together for 5 seconds to start compulsory defrosting, and  will be flashing. After defrosting,  will stop flashing.

(Note: Compulsory defrosting intervals should be more than 30 minutes and the compressor should run for more than 10 minutes.)

6 Wifi Setting

Please refer to page 23

2.3 MAINTENANCE AND WINTERISING

2.3.1 Maintenance



ATTENTION

Please don't forget to cut off power supply to the heat pump

- 1 Regularly clean the evaporator with household detergents or clean water. NEVER use gasoline, thinners or any similar fuel.
- 2 Check bolts, cables and connections regularly.
- 3 Every three months spray a surface insecticide on the surfaces around the unit to prevent any insect ingress.

2.3.2 Winterising - Sub Zero Climates

In climates where the winter season reaches sub-zero temperatures, please disconnect from power supply and drain water out of the heat pump. When using the heat pump under 2°C, make sure there is always water flow.

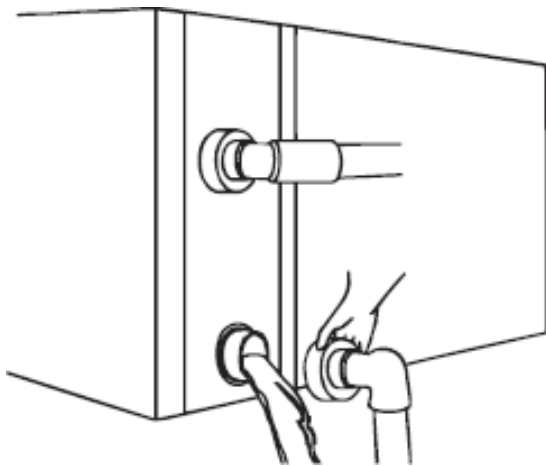

IMPORTANT

Unscrew the water union of inlet pipe to let the water flow out.

When the water in machine freezes in winter season, the titanium heat exchanger may be damaged.

3. TECHNICAL DATA OVERVIEW

Description	UoM	PL13HP	PL17HP	PL21HP	PL26HP	PL32HP
Maximum Pool Volume (m³) - Cool Climate	m³	30	40	50	70	80
Maximum Pool Volume (m³) - Warm Climate	m³	40	50	60	80	95
Operating air temperature		-15~43°C				
Performance Condition: Air 26°C, Water 26°C, Humidity 80%						
Heating capacity in Smart mode	kW	11	13.8	17.5	21.5	27
Heating capacity in Turbo mode	kW	13.2	16.8	21	25.5	31.5
COP in Smart mode		8.2	7.5	7.3	7.8	7.4
COP		7.3~15.0	6.4~15.5	6.3~15.0	6.8~16.0	6.3~15.8
COP at 50% capacity		11.6	11.2	11.2	11.3	11.2
Performance Condition: Air 15°C, Water 26°C, Humidity 70%						
Heating capacity in Smart mode	kW	7.3	9.4	11.8	14.8	18
Heating capacity in Turbo mode	kW	8.8	11.3	14.3	17.5	21.5
COP in Smart mode		5.3	5	5	5.4	5.3
COP		4.9~6.8	4.4~7.3	4.6~7.8	4.6~7.8	4.9~7.8
COP at 50% capacity		6.5	6.6	6.8	6.8	6.8
Sound pressure at 1m	dBA	38.6~46.9	42.0~47.7	42.9~50.8	40.8~51.2	43.3~51.9
Sound pressure of 50% capacity at 1m	dBA	41.3	43.7	44.5	44.4	46.4
Sound pressure at 10m	dBA	18.6~26.9	22.0~27.7	22.90~30.8	20.8~31.2	25.3~31.9
Power supply		230V/1 Ph/50Hz				
Advised water flux	litre/min	50~66	66~100	108~141	133~166	166~200
Fittings (Australian)		50mm				
Net Dimension	LxWxH	893x432x650	939x432x650	995x432x750	1125x429x952	1074x539x947
Net weight	kg	61	65	70	98	102
Compressor Type		Twin Rotary Mitsubishi DC-inverter				
Heat exchanger		Spiral titanium tube in PVC				
Casing		Premium Aluminium Alloy Casing (Matte Black)				

*The advised sizing is based on the pool being used for seasonal swimming with the use of a pool cover

- 1 The values indicated are valid under ideal conditions: Pool covered with an isothermal cover.
- 2 Related parameters are subject to adjustment periodically for technical improvement without further notice. For details please refer to nameplate.

4. TRANSPORTATION

- 4.1 When storing or moving the heat pump, please ensure the unit remains in an upright position at all times.

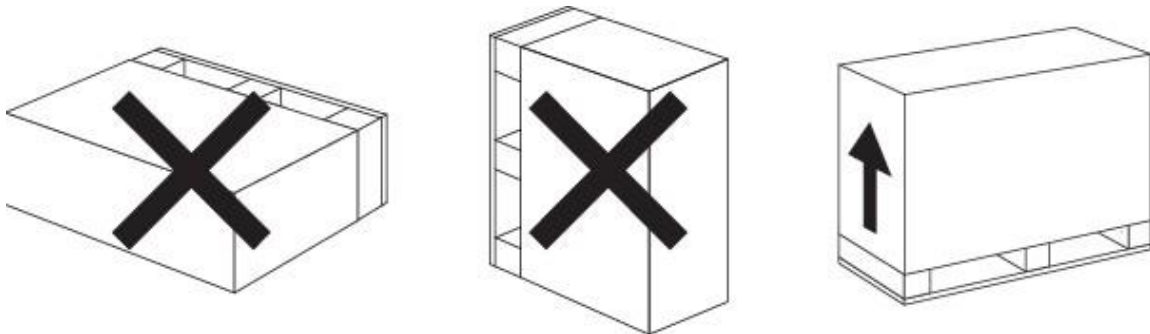

- 4.2 When moving the heat pump, do not lift the water union. This will damage the titanium heat exchanger.

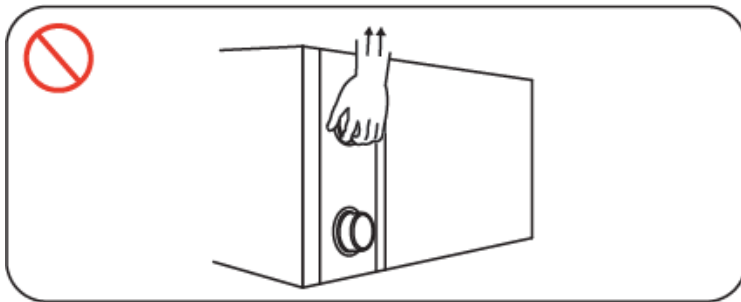

5. INSTALLATION AND MAINTENANCE



ATTENTION

It is strongly advised that the heat pump is installed by a professional. Unqualified installations may result in damage to the heat pump and/or safety risks to the user.

5.1 NOTICE BEFORE INSTALLATION

- 5.1.1 Plumbing connections must be made with solid PVC pipe. Usage of flexible PVC pipe is not recommended.

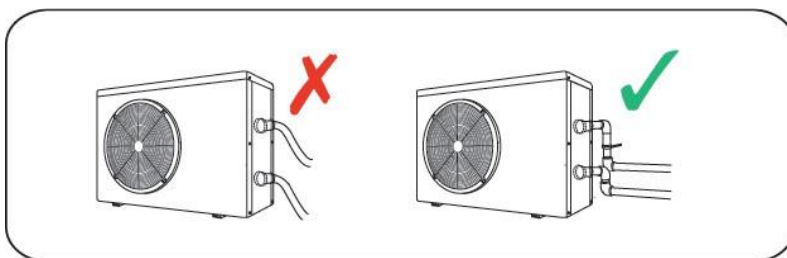

5.2 INSTALLATION INSTRUCTIONS

5.2.1 Location and size



ATTENTION

The heat pump should be installed in a place with good ventilation.

The heat pump is usually installed within a perimeter area extending 7.5m from the swimming pool. The greater the distance from the pool, the greater the heat loss in the pipes. As the pipes are mostly underground, the heat loss is low for distances up to 30m (15m from and to the heat pump; 30m in total) unless the ground is wet or the groundwater level is high. A rough estimate of the heat loss per 30m is 0.6 kWh (2,000 BTU) for every 5°C difference between the water temperature in the pool and the temperature of the soil surrounding the pipe. This increases the operating time by 3% to 5%.

Do not obstruct the air inlet or outlet of the heat pump. The efficiency may be reduced or even stopped.

SIDE DISCHARGE

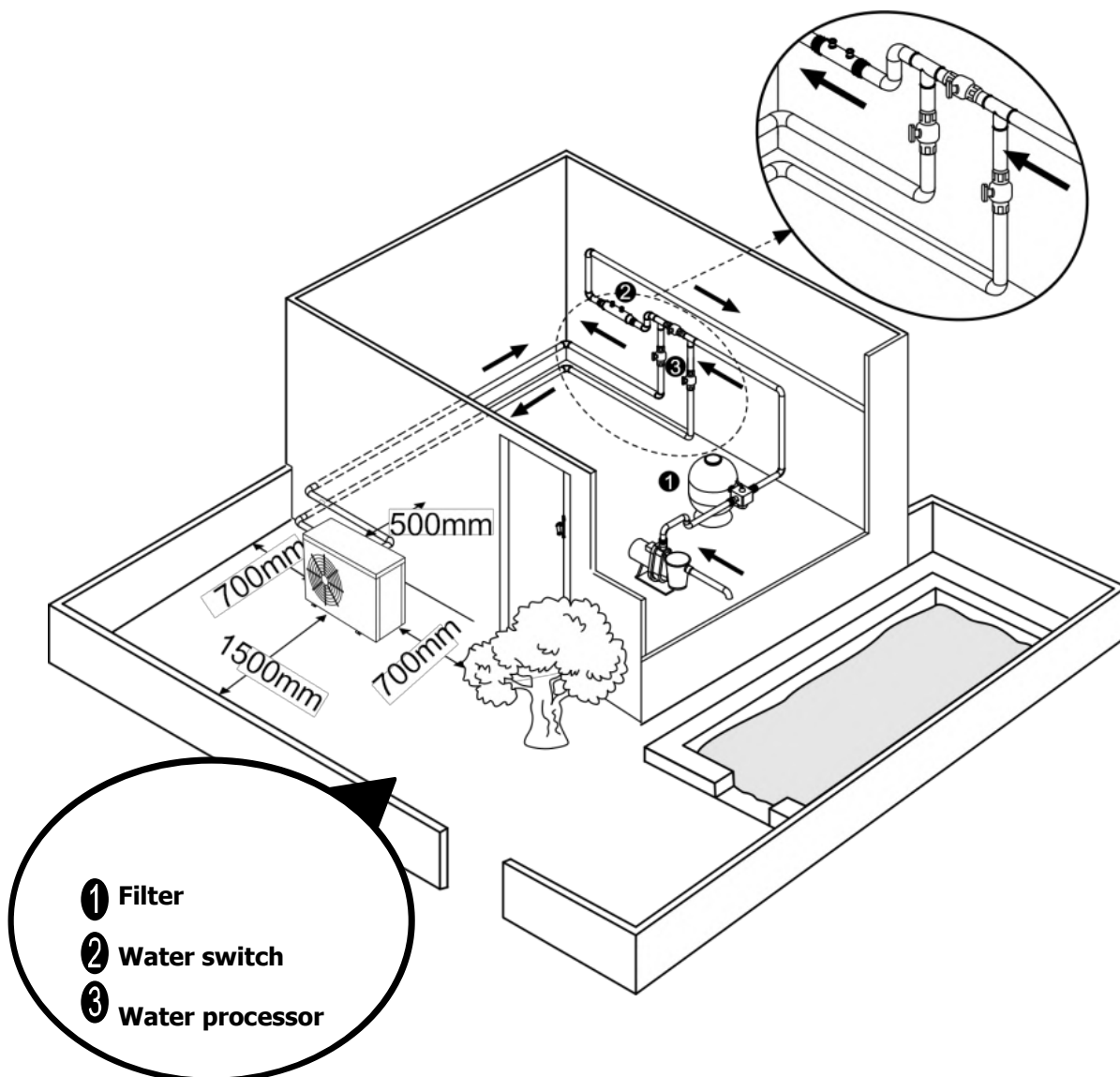

CHECK VALVE INSTALLATION



AUTOMATIC DOSING

Sanitation and automatic dosing systems must be plumbed after the heat pump. A check valve must be installed between the sanitation/automatic dosing system and the heat pump to prevent chemicals returning to the heat pump. Failure to observe this instruction will void the warranty.

INDEPENDENT SYSTEM

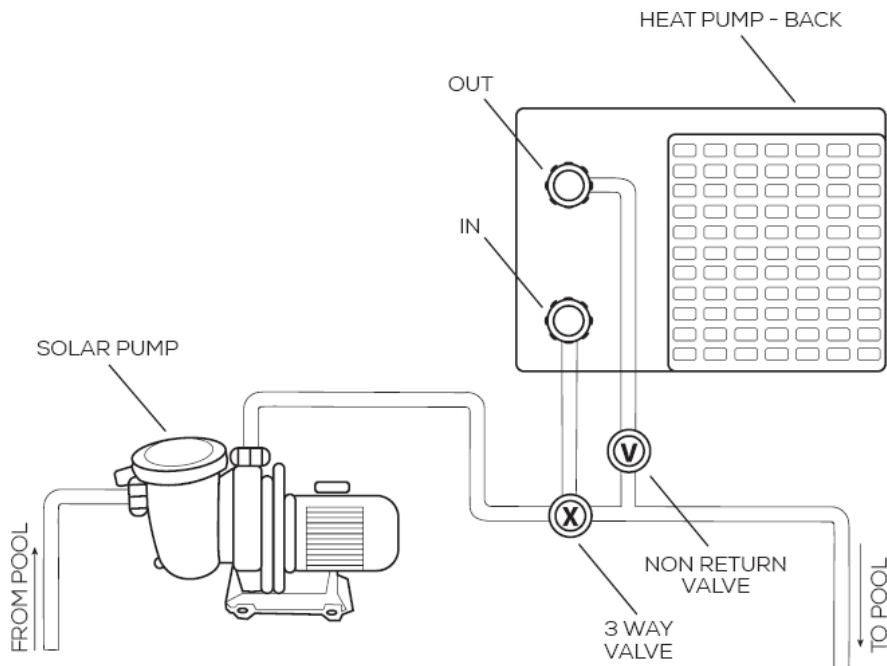

IN-LINE SYSTEM

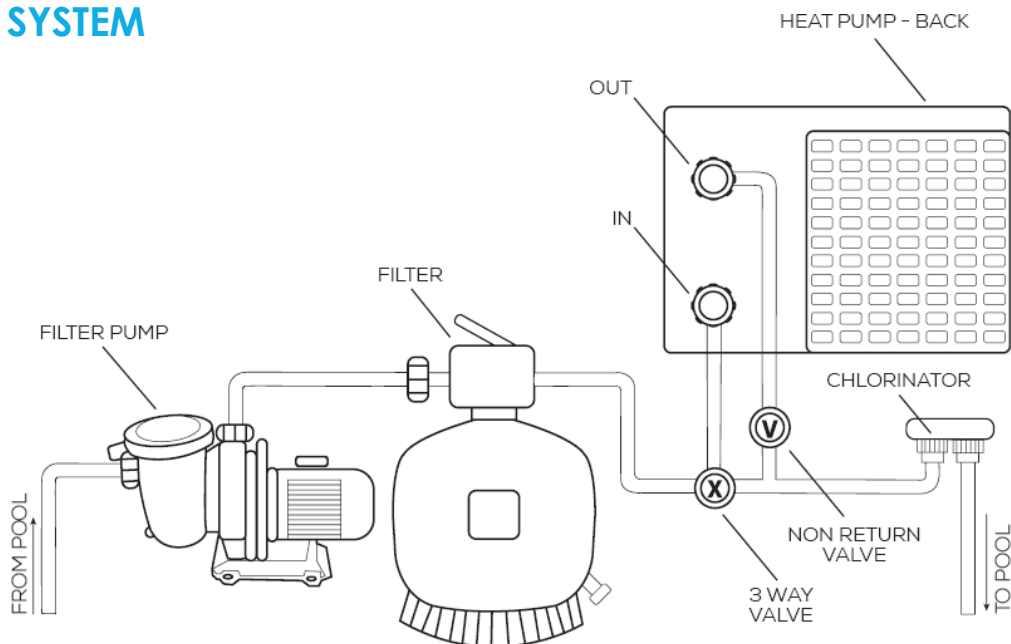

ADJUSTING THE BYPASS

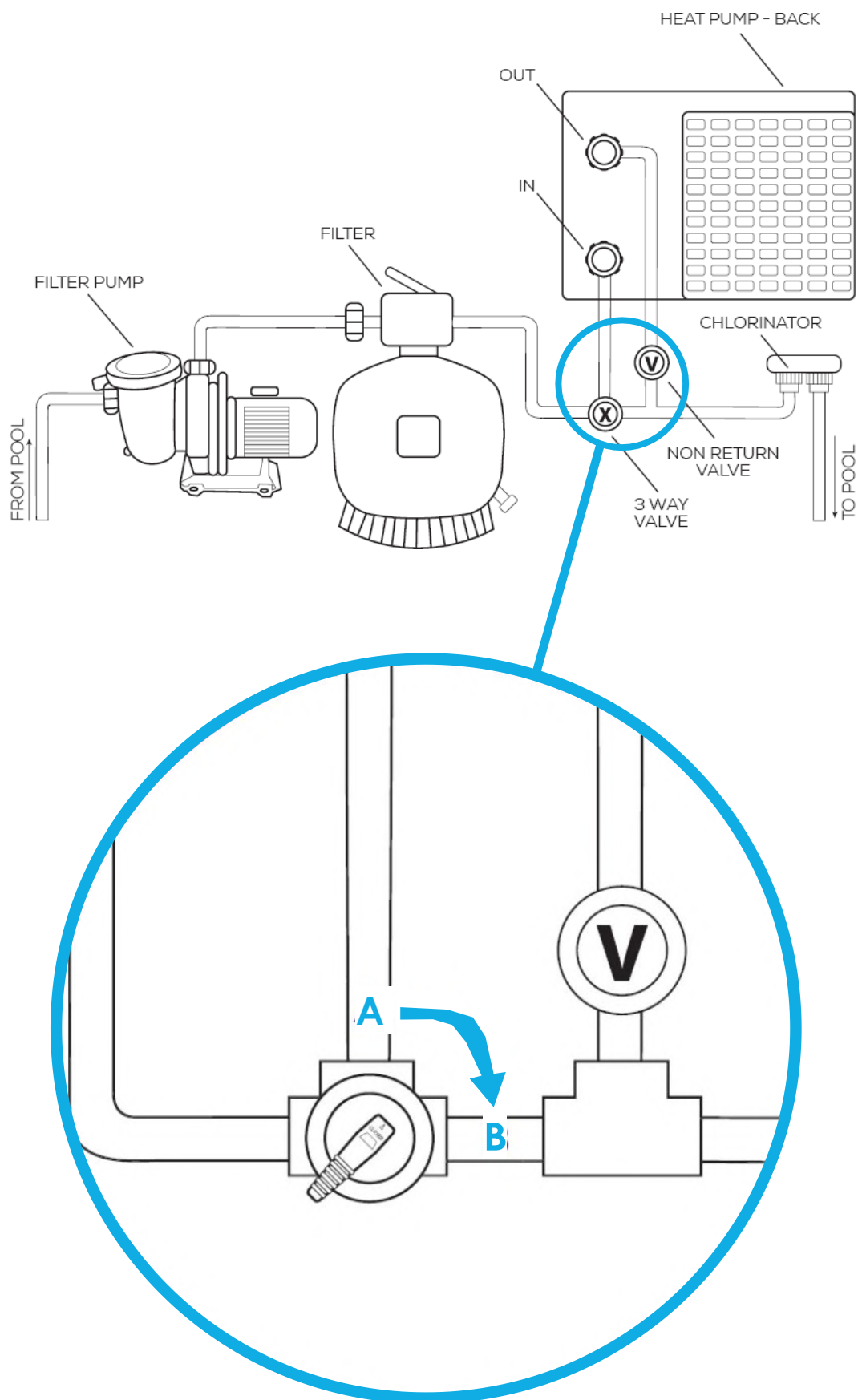

Use the following procedure to adjust the bypass:

- 1 Close the valve to Position A
- 2 Turn on the circulation pump
- 3 Slowly open the valve towards Position B until the display error code of "E6" disappears.
Once the message clears, the default display is the current water temperature.
Starting sequence will now begin.

ATTENTION



Bypass Installation

Operation without a bypass or with improper bypass adjustment may result in suboptimal heat pump operation and possible damage to the heat pump. Failure to observe this instruction will void the warranty.

DIMENSIONS

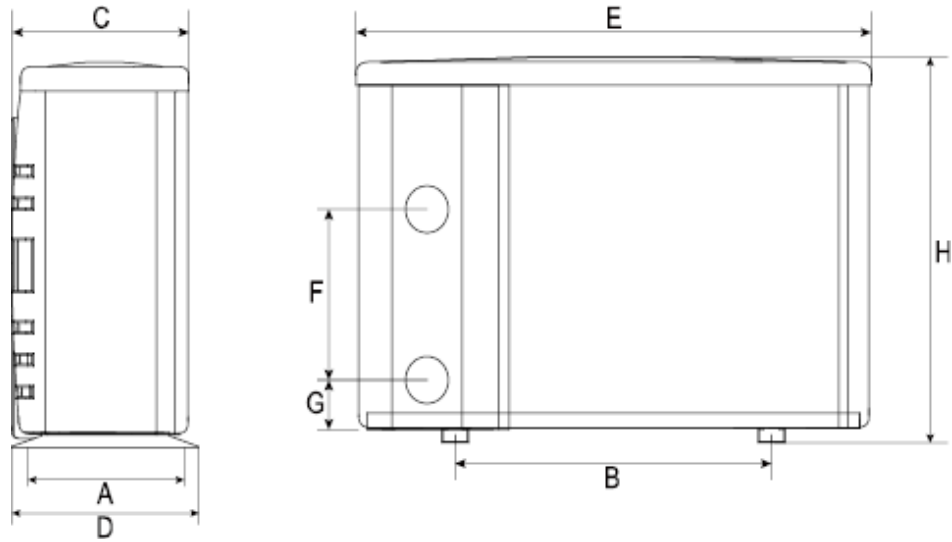

Unit = mm	A	B	C	D	E	F	G	H
PL13HP	407	528	390	432	893	280	74	650
PL17HP	407	574	390	432	939	350	74	650
PL21HP	407	630	390	432	995	460	74	750
PL26HP	407	760	384	429	1125	600	74	952
PL32HP	407	710	493	539	1074	640	74	947

*Above data is subject to modification without notice.

5.2.2 Heat Pump Installation

- When the heat pump is running, condensation will occur and drain from the bottom of the unit. This is completely normal. However, consideration should be made for how to drain the condensation away. Drainage nozzle and pipe are supplied.
- The frame must be fixed by bolts (**M10**) to concrete foundation or brackets. The concrete Foundation must be solid; the bracket must be strong enough and anti-rust treated.
- The heat pump needs a water pump (**Supplied by the user**). The recommended pump specification-flux: refer to Technical Parameter, Max. lift **≥10m**

5.2.3 Wiring & protecting devices and cable specification

- 1 Connect to appropriate power supply. The voltage should comply with the rated voltage of the unit.
- 2 Earth the machine well.
- 3 Wiring must be handled by a professional technician according to the circuit diagram.
- 4 Set leakage protector according to the local code for wiring (leakage operating current $\leq 30\text{mA}$).
- 5 The layout of power cable and signal cable should be orderly and not affect each other.



ATTENTION

Switch on after finishing all wiring construction and re-checking.

1. WIRING DIAGRAM

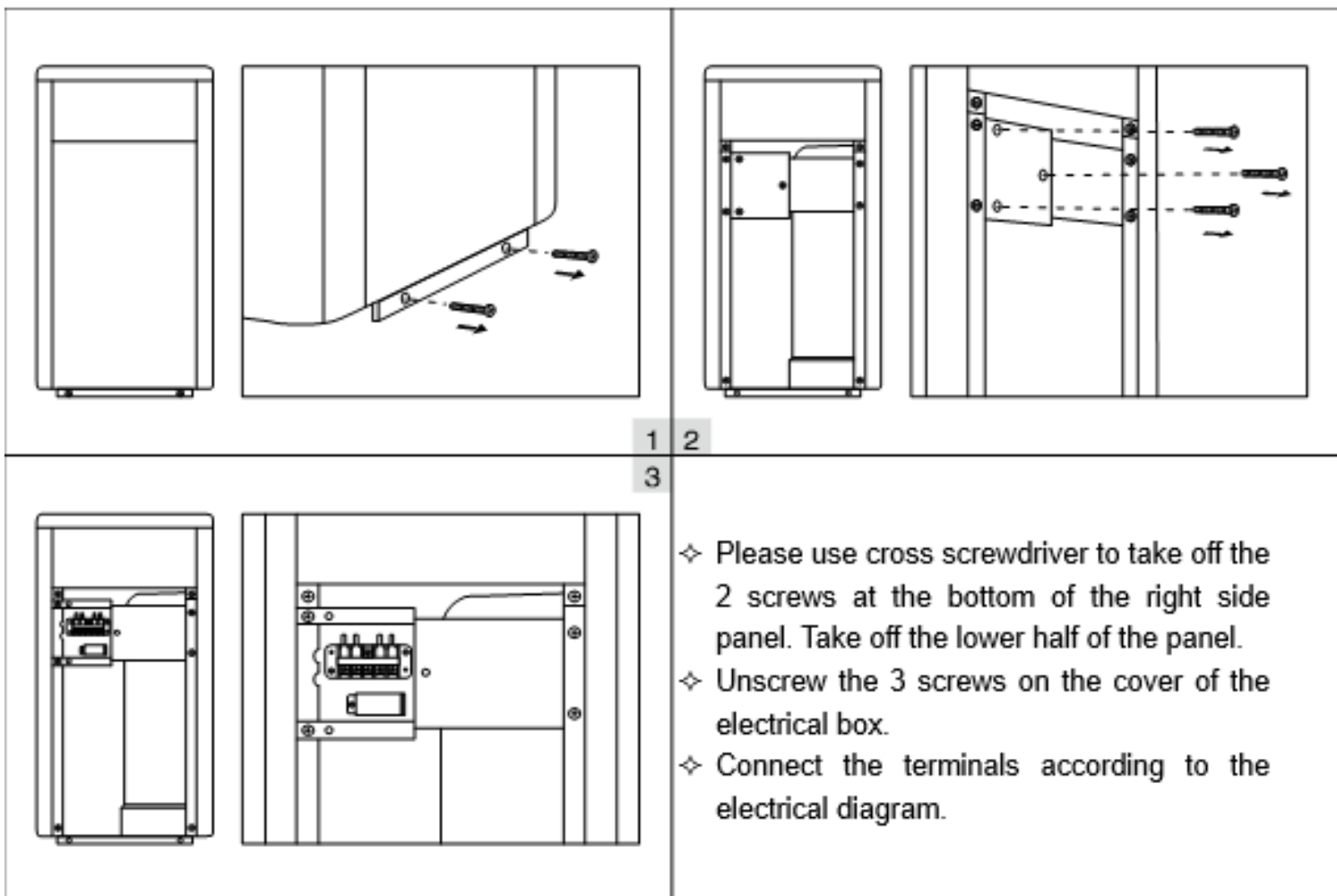

2. WIRING DIAGRAM

1 For power supply: **Single Phase 240V 50Hz**

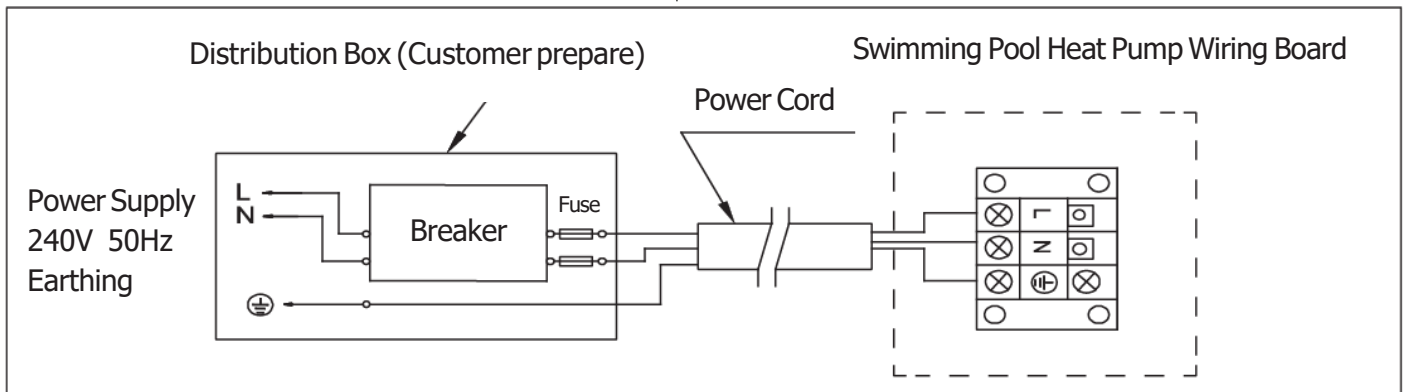

2 For power supply: **Three Phase 380V 50Hz**

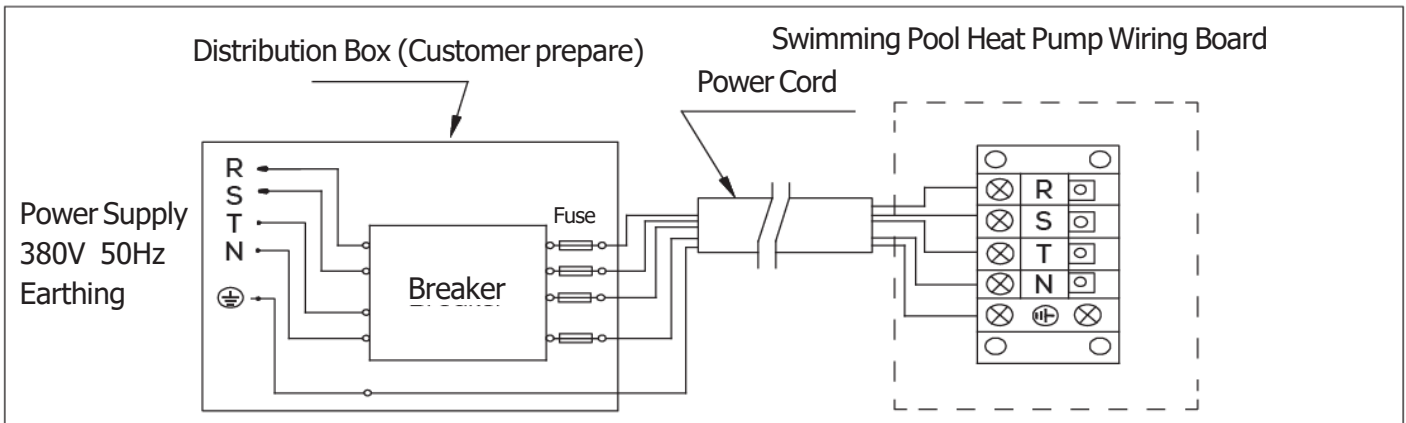

ATTENTION

For the detailed wiring diagram, please refer to Appendix 1.

OPTION FOR PROTECTING DEVICES AND CABLE SPECIFICATION

Model		PL13HP	PL17HP	PL21HP	PL26HP	PL32HP
Breaker	Rated Current A	15.0	19.0	22.5	24.5	28.5
	Rated Residual Action Current mA	30	30	30	30	30
	Fuse A	15.0	19.0	22.5	24.5	28.5
	Power Cord (mm ²)	3x2.5	3x4	3x4	3x6	3x6
	Signal Cable (mm ²)	3x0.5	3x0.5	3x0.5	3x0.5	3x0.5

NOTE: The above data is adapted to power cord $\leq 10m$. If power cord is $>10m$, wire diameter must be increased. The signal cable can be extended to 50m at most.

5.3 TRIAL AFTER INSTALLATION



ATTENTION

Please check all the wirings carefully before turning on the heat pump.

5.3.1 Inspection before use

- 1 Check installation of the whole heat pump and the pipe connections according to the pipe connecting drawing.
- 2 Check the electric wiring according to the electrical wiring diagram and earthing connection.
- 3 Make sure that the main power is well connected.
- 4 Check if there is any obstacle in front of the air inlet and outlet of the heat pump.

5.3.2 Trial

- 1 The user is advised to start the water pump before the heat pump and turn off the heat pump before the water pump for long life circle.
- 2 The user should start the water pump, and check for any leakage of water; power on and press the ON/OFF button of the heat pump and set desired temperature in the thermostat.
- 3 In order to protect the heat pump, the heat pump is equipped with a start delay function. When starting the heat pump, the fan will start to run in 3 minutes, in another 30 seconds, the compressor will start to run.
- 4 After pool heat pump starts up, check for any abnormal noise from the heat pump.
- 5 Check the temperature setting.

6. TROUBLE SHOOTING GUIDE

Failure	Reason	Solution
Heat pump doesn't run	No power	Check there is power going to the unit
	Power switch is off	Switch on the power
	Fuse burned	Check and change the fuse
	The breaker is off	Check and turn on the breaker
Fan running but with insufficient heating	Evaporator blocked	Remove the obstacles
	Air outlet blocked	Remove the obstacles
	3 minutes start delay	Wait patiently
Display normal, but no heating	Set temperature too low	Set proper heating temp.
	3 minutes start delay	Wait patiently

Display	Description	Reasons/Solutions
E3	Insufficient or no water flow/ protection	<p>Ensure water flow through circulating pump/filtration system;</p> <ol style="list-style-type: none"> <ol style="list-style-type: none"> Ensure circulating pump is primed (independent system). Ensure water flow through filtration i.e. filter pump is primed, check filter pressure, visible water flow (inline system). Adjust flow through bypass valve in order to direct more flow to heat pump (specific to plumbing configuration). Possible blockage. Check flow switch and PCB wiring (technician only).
E5	Power (voltage) supply outside acceptable operating range	Engage electrician to confirm power supply (refer to technical specifications).
E6	Excessive temperature differential between inlet and outlet water (insufficient water flow/protection)	<p>Ensure water flow through circulating pump/filtration system.</p> <ol style="list-style-type: none"> <ol style="list-style-type: none"> Ensure circulating pump is primed (independent system). Ensure water flow through filtration i.e. filter pump is primed, check filter pressure, visible water flow (inline system). Adjust flow through bypass valve in order to direct more flow to heat pump (specific to plumbing configuration). Possible blockage.
Eb	Ambient temperature too high or too low protection	Wait until air temperature returns to heat pump operating range (refer to technical specifications).
Ed	Anti-freezing reminder	<p>Anti-freeze mode is activated;</p> <p>When water inlet temperature $\leq 2^{\circ}\text{C}$ and air temperature $\leq 0^{\circ}\text{C}$, heat pump will automatically start running in heating mode.</p> <p>When water inlet temperature $\geq 15^{\circ}\text{C}$ or air temperature $\geq 1^{\circ}\text{C}$, heat pump will be powered off or on standby.</p>

NOTE: If the above solutions don't work, please contact your installer with detailed information and your serial number.

7. ERROR CODES

NO.	Display	Failure Description
1	E1	High pressure protection
2	E2	Low pressure protection
3	E4	Phases lack protection (three phase model only)
4	E7	Water outlet temp too high or too low protection
5	E8	High exhaust temp protection
6	EA	Evaporator overheat protection (only at cooling mode)
7	P0	Controller communication failure
8	P1	Water inlet temp sensor failure
9	P2	Water outlet temp sensor failure
10	P3	Gas exhaust temp sensor failure
11	P4	Evaporator coil pipe temp sensor failure
12	P5	Gas return temp sensor failure
13	P6	Cooling coil pipe temp sensor failure
14	P7	Ambient temp sensor failure
15	P8	Cooling plate sensor failure
16	P9	Current sensor failure
17	PA	Restart memory failure
18	F1	Compressor drive module failure
19	F2	PFC module failure
20	F3	Compressor start failure
21	F4	Compressor running failure
22	F5	Inverter board over current protection
23	F6	Inverter board overheat protection
24	F7	Current protection
25	F8	Cooling plate overheat protection
26	F9	Fan motor failure
27	Fb	Capacitor no charging protection
28	FA	PFC module over current protection



ATTENTION

Please contact your installer with detailed information and your serial number.

8. WIFI SETTING

1 App Download



iPhone please download from

Android mobile please download from



2 Account Registration

1 Registration by mobile number/email

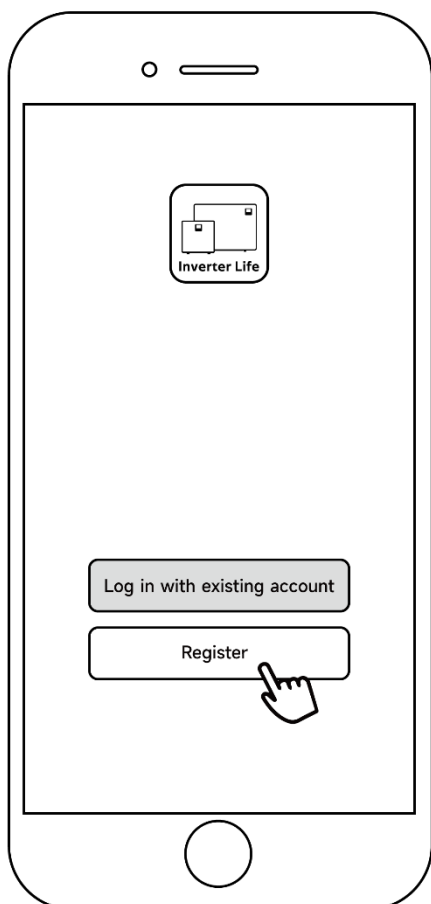

WIFI SETTING

2 Mobile number registration

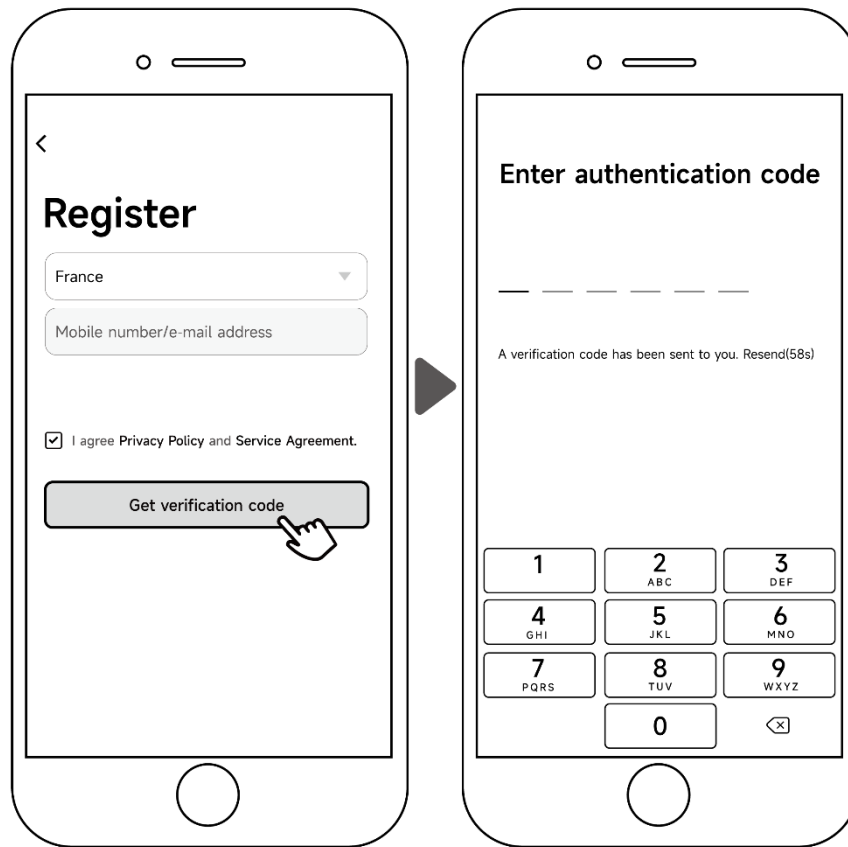

3 Create family

Please set family name and choose the room of device

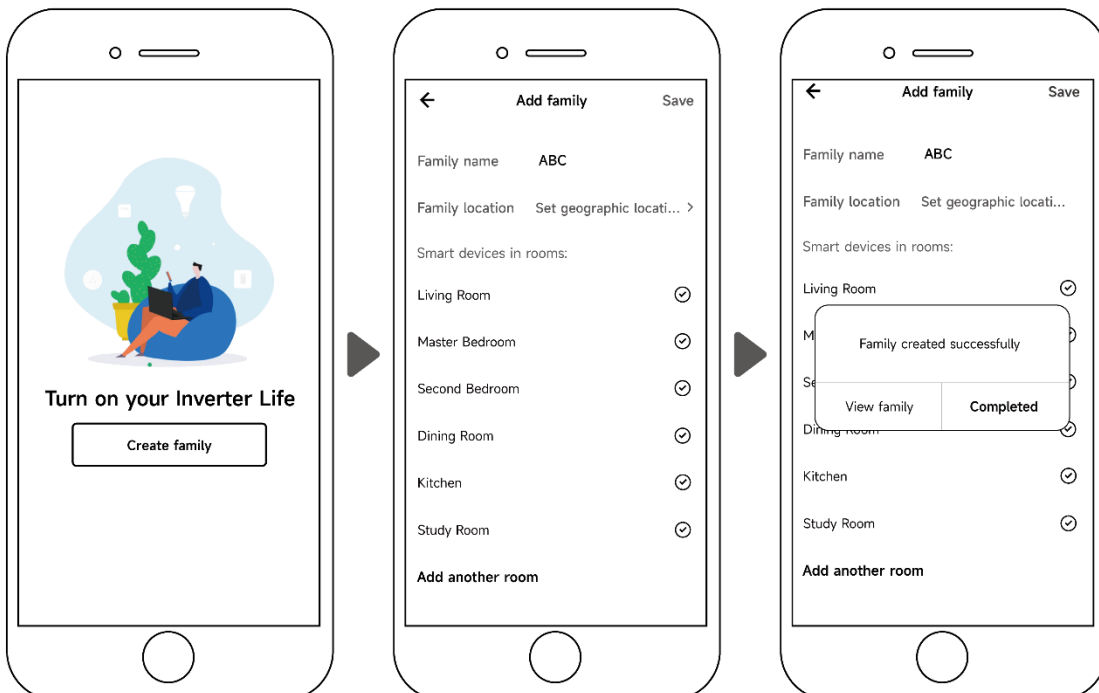

WIFI SETTING

4 APP Binding

Please make sure your mobile phone has connected to Wifi



A Wifi Connection

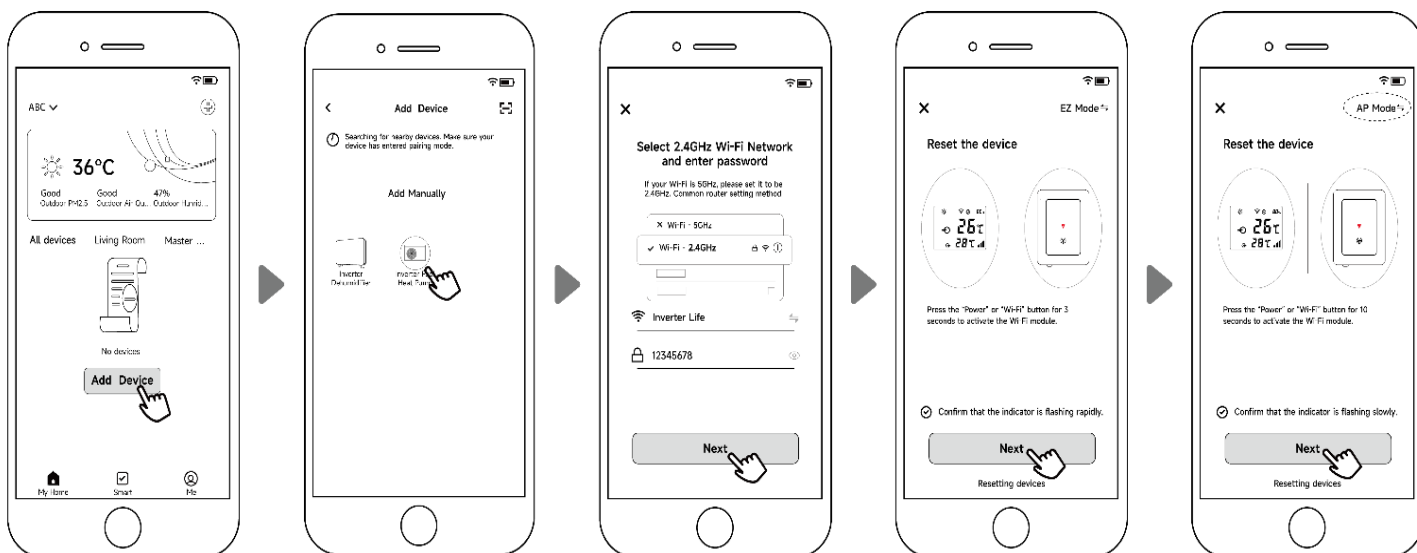

Press  for 10 seconds after screen unlock,  will be flashing slowly to enter Wifi binding program.

B Click "Add device", follow indication to finish binding.  display on the screen once Wifi connection success.

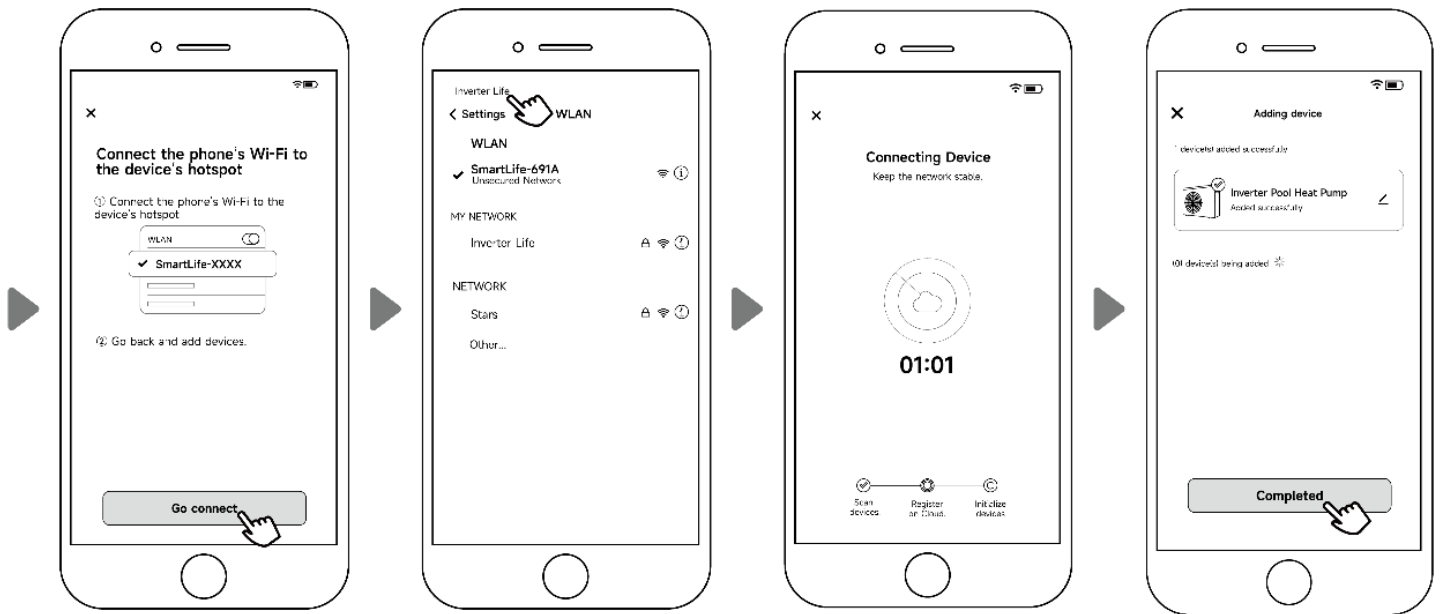



Note: If it doesn't jump automatically, click "Confirm hotspot connection, next".

- C** If connect fails, please make sure your network name and password is correct. And your router, mobile phone and device are as close as possible.
- D** Wifi rebinding (When Wifi password changes or network configuration changes):
Press  for 10 seconds,  will be flashing slowly for 60 seconds. Then  will be off. The original binding will be removed. Follow step above for rebinding.

(Remarks: Please make sure the router is configured at 2.4G. 5G networks are NOT compatible.)

WIFI SETTING

5 Operation

For heat pump with Heating function only.

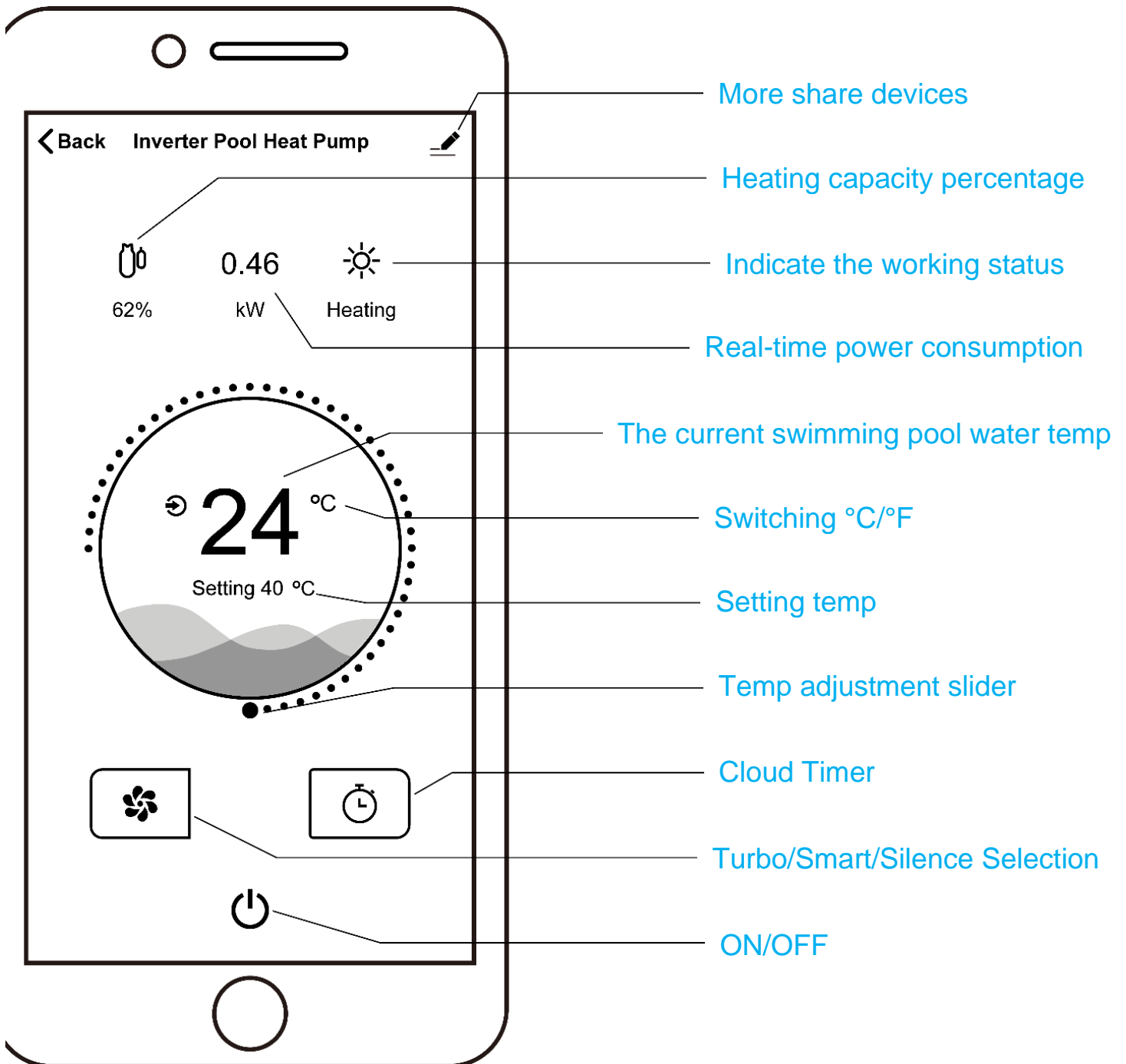

WIFI SETTING

6 Share devices to your family members

After binding, if your family members also want to control the device.

Please let your family members register the APP first, and then the administrator can operate as below:

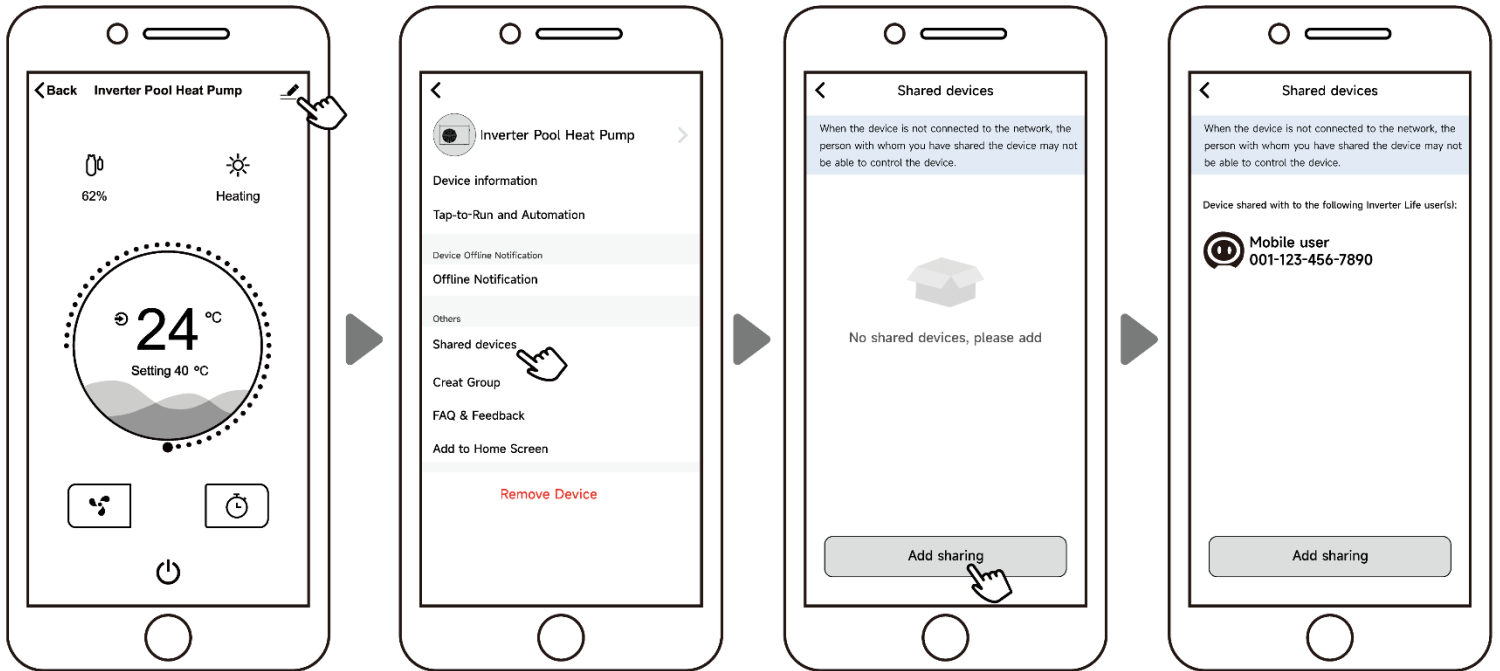

WIFI SETTING

Then your family members can log in as below:

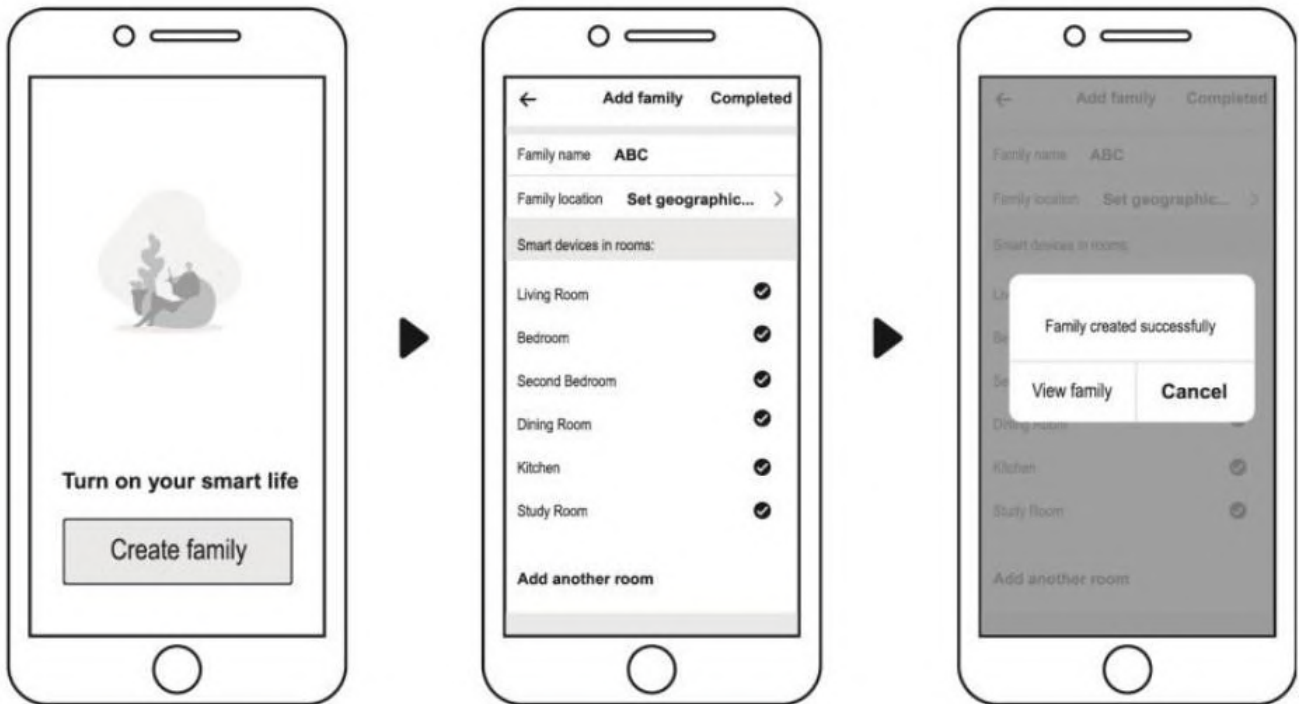

NOTE

- The weather forecast is just for reference.
- APP is subject to updating without notice.



sales@bossolar.com.au

www.bossolar.com.au

1300 786 489



Scan to access

Boss Polymer Technologies Pty Ltd
Terms and Conditions of Trade